



Bright House Networks
Digital Phone)))
 Calling Feature Instructions

Managing Voice Mail Messages

Pin # _____

Retrieving Messages at Home

A stuttering dial tone will alert you to waiting messages.

Press (*) 98

OR

Dial your home phone number and listen for prompts

On-Line Feature

With Digital Phone Online Tools you can manage and listen to your voicemail, reset your PIN, and more.

For more information please visit our web site:

michigan.mybrighthouse.com/my_account

Retrieving Messages Away From Home

1. Dial your home phone number. Wait for your voice mail to answer and then press star (*) 5.
2. Enter your PIN and press pound (#).
3. Press the 1 key to hear voice mail messages.

Saving a Voice Mail Message

Press the pound (#) key at the end of the message. Voice mail will save the message and play the next message automatically.



Bright House Networks

Digital Phone)))

Calling Feature Instructions

• Unlimited local calls • In-State Calls • Long Distance in the U.S.

Digital Phone Contact Information)))

Customer Service Phone Hours

Mon. - Fri., 7:00 a.m. - 7:00 p.m.
 Sat., 7:00 a.m. - 5:00 p.m.

Customer Support Numbers

REDFORD

Customer Service	313-538-1313
24 Hour Service and Repair	313-538-5115

LIVONIA

Customer Service	734-422-3200
24 Hour Service and Repair	734-422-3410

OAKLAND COUNTY

Customer Service	248-553-7300
24 Hour Service and Repair	248-553-7307

Office Locations and Hours

LIVONIA

14525 Farmington Rd.
 Mon. - Thu., 8:30 a.m. - 7:00 p.m.
 Fri., 8:30 a.m. - 6:00 p.m.
 Sat., 9:00 a.m. - 2:00 p.m.

OAKLAND COUNTY

37635 Enterprise Ct.
 Mon. - Thu., 8:30 a.m. - 7:00 p.m.
 Fri., 8:30 a.m. - 6:00 p.m.
 Sat., 9:00 a.m. - 2:00 p.m.



Welcome)))
 Digital Phone Kit



Quick Start Guide From Home

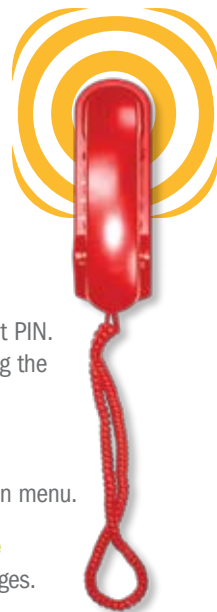

- **Set Up Your Voice Mail**
 1. Dial your home phone number.
 2. As a first-time user, you will be prompted to enter a temporary PIN – the last four digits of your phone number.
 3. Follow the prompt to select a permanent four-digit PIN. Press pound (#). Confirm your new PIN by entering the PIN again and pressing pound (#).
 4. Say your name and press pound (#).
 5. Record your greeting and press pound (#).
 6. Once set-up is complete, you can return to the main menu.

- **Retrieve Voice Mail Messages From Home**

A stuttering dial tone will alert you to waiting messages. Press (*) 98
OR
Dial your home phone number and listen for prompts

- **On-Line Feature**

With Digital Phone Online Tools you can manage and listen to your voicemail, reset your PIN, and more. For more information please visit our web site: michigan.mybrighthouse.com/my_account

- **Caller ID**

If your telephone is Caller ID-capable, the name and number of your caller will be displayed after the first ring. If “P” or “Private” is displayed, the name and number may have been blocked by the caller. If “Unknown Name,” “Unknown Number,” “Out Of Area” or “O” appear, the call is from an area that doesn’t support Caller ID services.

- **Call Waiting**

A special tone alerts you to a waiting call; your caller hears regular ringing. To answer, press and release the “Receiver” or “Flash” buttons, and the first caller will be placed on hold. To end either call, hang up. Pick up the automatic ring, and you’ll be connected with the new caller.

For more detailed information, please turn to the How-To Guide. If you need additional help, go to www.michigan.mybrighthouse.com or dial 611 on your Bright House Networks Digital Phone.

Thank you for choosing Digital Phone, the residential telephone service from Bright House Networks. We are confident that you will enjoy the great value and convenience of Digital Phone service, which offers unlimited local and long distance calling anywhere in the U.S., Puerto Rico and Canada, as well as the most popular calling features at no extra charge.

Digital Phone works just like your regular phone. You will be able to use the phones you already have, and in most cases you will be able to keep your existing phone number. For answers to all of your Digital Phone questions, go to www.michigan.mybrighthouse.com. You can call us at **611** from your Digital Phone or **(866) 898-9101** from any other phone.

Following are several **Frequently Asked Questions**, and a **How-To Guide**. For **Troubleshooting Tips**, turn to the back page of this booklet.

Thank you)))

Try these self-help steps.

- **Static** can be eliminated, in most cases, by moving the cordless station away from the phone modem.
- **To check for an in-house wiring problem (no dial tone, clicking, static),** remove the phone line from the wall jack and put it directly into the Line 1 port located at the back of your phone modem. If this resolves the problem, you may need assistance with your in-house wiring. Please call our Support Desk to schedule a free service appointment by dialing 611.
- **If the problem persists, try resetting the phone modem.** You can do this by pressing the reset button at the back of the modem. You will need to use a toothpick or the point of a pencil. Within a few minutes, your dial tone should be restored or other problem resolved. Reconnect your phone line to the wall jack.
- **If you still don’t hear a dial tone after resetting,** notify our Support Center for a free service appointment by dialing your local customer support number (see back cover).
- **If you are unable to call or accept specific numbers:** Call our Support Center by dialing 611. Please have information available about the numbers you called, as well as the dates and times.
- **If your phone indicates that a message is waiting, but you can’t retrieve it:** From the Voice Mail main menu, press 1 and then press 3 to release the system. This will allow you to retrieve your messages.
- **If you experience a loss of Internet service:** Press the standby button located on the front or the top of your Digital Phone modem (depends on manufacturer). Connectivity should be restored. If this does not resolve your problem, try resetting the modem as described above.
- **If a power outage occurs:** If the phone modem has backup battery, plug a corded phone directly into the back of the modem (Line 1) to make and receive phone calls.
- **Always connect the cable before connecting power.**



If you still need to call repair, dial 611 on your Bright House Networks Digital Phone or (866) 898-9101 from any other phone.

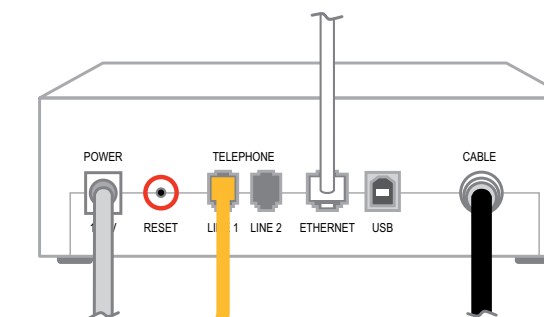

Troubleshooting Tips

Replaying a Voice Mail Message

Press the 1 key when the message is complete. Voice mail will replay the message.

Managing Voice Mail Messages

Replaying to a Voice Mail Message

The message must be from another Bright House Networks Digital Phone.

1. Press the 2 key, after you have retrieved and listened to the message.
2. Follow prompts to record your reply and send it to your caller.

Erasing a Voice Mail Message

Press the 3 key at the end of the message.

Retrieving an Accidentally Erased Message

Press the star (*) and 7 keys to back up to the deleted message. You can save the message by pressing the pound (#) key or erase the message by pressing 3.

Call Forwarding From a Touch Tone Phone

1. Dial star (*) 72, and wait for the dial tone.
2. Enter the number where you’d like your calls to be forwarded.
3. The feature is activated when the courtesy call is answered by the forwarded-to party, or if the call is picked up by voice mail.
4. Calls will continue to be forwarded until the feature is deactivated.
5. To cancel Call Forwarding, dial star (*) 73.

Reminder: Charges generated by calls forwarded to international numbers will be the responsibility of the customer. Minutes used during calls forwarded to cell phones will be charged against the customer’s wireless plan.